

Curtis "Woody" Baird
Mayor
Stephanie J. Southerland
City Clerk
Romy Stamps
Finance Director



CITY COUNCIL
Audrey "Buffy" Colvin
Council President
Scott Hardy
President Pro Tempore
Bobby L. Tapley
John Eric Brown
Chris Brown
Jimmy Keel

281 James D. Nabors Drive • Alexander City • Alabama 35010 • (256) 329-6700
www.alexandercityal.gov

BID 24-07
CITY OF ALEXANDER CITY, ALABAMA
PUBLIC WORKS DEPARTMENT
SUPPLIES FOR PAVING PREPARATION

The City of Alexander City, Alabama, is requesting bids for the purchase of paving supplies for utilization by the Public Works department, per the attached specifications. A full copy of the bid and all addendums may be obtained at [<https://alexandercityal.gov/rfps>]. Proposals must be submitted in writing to the Alexander City Clerk's office no later than February 19th, 2024. **Please place the proposals bid number and opening date on the outside of the envelope.** Proposals must be mailed or hand delivered to the address below. No proposals will be allowed to be submitted via fax or email.

Pre-Qualifications: There are no pre-qualifications for this bid.

ADDRESS ALL RETURN ENVELOPES TO: CITY OF ALEXANDER CITY
CITY CLERK'S OFFICE
281 JAMES D NABORS DR.
ALEXANDER CITY, ALABAMA 35010

BID SOLICITATION SCHEDULE

Public Notice of Bid:	February 1 st , 2024
Question Submission Deadline:	February 9 th , 2024
Bid Due Date:	February 19 th , 2024 at 2:00pm CST
Evaluation Period:	February 19 th – March 1 st , 2024
Anticipated Award Date:	March 4 th , 2024

Contract Terms and Conditions

The City of Alexander City will publicly open and read aloud all bids on the date and time listed above. Bids are to be opened by the City Clerk at City Hall located at 281 James D Nabors Dr, Alexander City, Alabama. Bidders and authorized representatives are invited to be present at any bid opening.

Bids shall not be modified after the opening. Prices and notations should be in ink or typewritten on the form provided by the owner. All bid prices must be fully extended. Bids must conform to any attached detailed specifications to be eligible for consideration.

The contract shall begin on the date of the bid approval by the awarding authority. The anticipated award date for this contract is **March 4th, 2024**.

All Federal, State, and Local License and Fee requirements will be applicable.

The City of Alexander City shall be responsible for the pickup of vehicles from the respected vendor.

No sales taxes of any kind are to be included in the bid prices. The City of Alexander City will furnish tax exemption certificates when necessary.

All prices and percentages must be firm for a minimum of 60 days.

Bidder must grant the City of Alexander City a 30-day net payment terms without penalty.

Bid awards will not be official until bidder is formally notified by receipt of purchase order.

Invoices shall be submitted by email to Accounts Payable at [ap@alexandercityal.gov] or by mail to:

City of Alexander City
Attn: Accounts Payable
281 James D Nabors Dr.
Alexander City, AL 35010

The City of Alexander City prefers contracts that provide a sole source responsibility for all products and services provided. If the proposer requires the use of a third-party dealer, reseller or subcontractors to provide products or services, the proposer shall list the third party to be used and address how the products or services will be delivered.

In accordance with the State of Alabama Law, a 5% variance consideration may be given to those vendors located within the City of Alexander City, City Limits and Police Jurisdiction. By Section 41-16-5, Code of Alabama 1975, with the submittal of a bid, the prospective vendor represents and agrees that it is not currently engaged in, nor will it engage in, any boycott of a person or entity based in or doing business with a jurisdiction with which the State of Alabama can enjoy open trade.

If the vendor employs any persons in the State of Alabama, in accordance with Section 31-13-9, Code of Alabama 1975, Proposers shall demonstrate proof of enrollment in the E-verify program by completing the enclosed E-verify affidavit, or providing some other proof of enrollment. If the proposer employs persons (anywhere), the award of the bid is condition on the bidder not knowingly employing, hiring for employment, or continuing to employ an unauthorized alien within the State of Alabama. Upon awarding of the contract where a written contract is to be signed, the contract will contain a provision whereby the bidder promises not to violate Federal Immigration Law.

Questions and Communications Regarding this Bid

All communications must be in writing, sent by email to Allison Bishop, Public Works [allison.bishop@alexandercityal.gov], Romy Stamps, Finance Director [romy.stamps@alexandercityal.gov], and Stephanie Southerland, Alexander City Clerk [stephanie.southerland@alexandercityal.gov]. The subject line of the email must include “Bid 24-07”. All questions must be received no later than February 9th, 2024 at 5:00pm CST.

A running response to all vendors’ questions will be provided as an addendum. The addendum can be found on the City’s website at [<https://alexandercityal.gov/rfps>].

Evaluation

The award will be made to the Bidder whose proposal conforms to all conditions and requirements within the specifications of this bid. In addition, the City of Alexander City reserves the right to consider the following during the evaluation period:

- a) Award bids by Lump Sum or individual items unless otherwise noted by bidder. NOTE: No purchase will be made on Lump Sum awards until individual unit prices are furnished.
- b) Award the bid to the lowest or best bidder, as determined by the Owner to be in the best interest of The City of Alexander City. Life cycle/maintenance costs will be taken into consideration.
- c) Reject any or all bids and to waive technicalities when in the opinion of the City of Alexander City the best interest of The City of Alexander City will be served.
- d) Make null and void the purchase order with the successful bidder if delivery cannot be made at the specified time.
- e) In accordance with the State of Alabama Law, a 5% variance consideration may be given to those vendors located within the City of Alexander City, City Limits and Police Jurisdiction.
- f) Ability to deliver goods and services in a timely manner.
- g) Warranty
- h) Suitability for use by the owner.

BID 24-07
CITY OF ALEXANDER CITY, ALABAMA
PUBLIC WORKS DEPARTMENT
SUPPLIES FOR PAVING PREPARATION

Proposer (Vendor) Name: _____
Representative: _____
Address: _____
City: _____
State, Zip Code: _____
Phone: _____
Email: _____

Total Bid Amount \$ _____

Will be able to make delivery in full within _____ (number of) _____ (days or weeks) upon receipt of the purchase order.

Do all items bid meet or exceed the required specifications? ____ Y/N If no, please highlight and provide documentation detailing the reason for the deviation from the specifications.

If this is the first time you have conducted business with the City of Alexander City, please include a copy of your W-9 and remittance information. Included ____ Y/N

Non-Collusion Statement: By signing this bid form, the bidder certifies that this bid is made without reference to any other bid and without any agreement, understanding, collusion or combination with any other person(s) in reference to the bid.

Signature of Bidder Representative: _____

Date Signed: _____

STATE OF:

COUNTY OF:

AFFIDAVIT

Before me, the undersigned authority, personally appeared _____ (affiant) who, being by me first duly sworn, doth depose and say as follows:

I _____ (name), on behalf of _____ (business entity), and with lawful authority to act in its behalf, attest to the following from personal knowledge:

1. _____ (business entity) does not knowingly, hire for employment, or continue to employ any unauthorized aliens in the State of Alabama; and
2. _____ (business entity) is enrolled in the E-Verify Program as shown by the attached documentation; and
3. _____ (business entity) does and will utilize E-Verify Program to verify the employment status of employees and potential employees according to federal rules and regulations; and
4. _____ (business entity) shall acquire from its subcontractors notarized affidavits that they will not knowingly employ, hire for employment or continue to employ unauthorized aliens, that they will enroll in the E-Verify Program before performing any contract work or providing any product, and that they shall attach to the affidavits, documentation establishing their enrollment in E-Verify as required by Act No. 2011-535.

Signature of Affiant

I, the undersigned Notary Public, in and for said County and State, hereby certify that whose name is signed to the foregoing Affidavit, and who is known to me, acknowledged before me on this date that, being informed of the contents of the above and foregoing affidavit, he/she as an officer of _____ (business entity) and with full authority, executed the same voluntarily for and as the act of said company on the day the same bears date.

Given under my hand and official seal of office this _____ day of _____, _____.

Notary Public

TRADE REFERENCE FORM

Name of Government Organization or Business: _____

Point of Contact: _____ Phone: _____

Address: _____ State: _____ Zip: _____

Scope of Project(s) Completed or Description of Item(s) Sold: _____

Name of Government Organization or Business: _____

Point of Contact: _____ Phone: _____

Address: _____ State: _____ Zip: _____

Scope of Project(s) Completed or Description of Item(s) Sold: _____

Name of Government Organization or Business: _____

Point of Contact: _____ Phone: _____

Address: _____ State: _____ Zip: _____

Scope of Project(s) Completed or Description of Item(s) Sold: _____

SPECIFICATIONS

BID LIST 24-07 CITY OF ALEXANDER CITY, ALABAMA PUBLIC WORKS DEPARTMENT-SUPPLIES FOR PAVING PREPARATION						
Product Discription	Quantiy	Unit of Measure	Unit Price	Extended Price	Manufacturer of Product	Model No.
1" Riser Rings for Valve Boxes	116	Each				
2" Riser Rings for Valve Boxes	100	Each				
1" Riser Rings for Manhole	100	Each				
6" Riser Rings for Manhole	10	Each				
Casting with Lid (No vent holes)	80	Each				
		TOTAL BID PRICE		\$		
Reminder: Parts must be compatible with Sigma manholes currently in place throughout the City.						
Casting and lid: MH-3104N						
1" Riser for Manhole: MH-2410						
6" Riser for Manhole: MH-2460						
Gas and water needs parts to be compatible with Sigma VB2600 round valve boxes.						
1" Riser Rings- Sigma VB2601						
2" Riser Rings- Sigma VB2602						
Additonal spec sheets will be attached.						

***The city will pick up material if the vendor is local to save on additional shipping cost.**

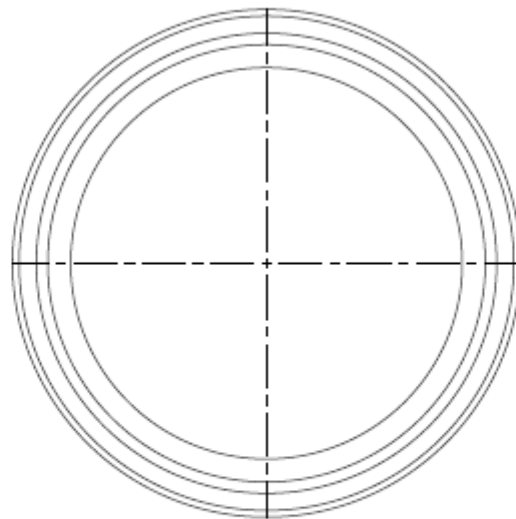

PLAN VIEW

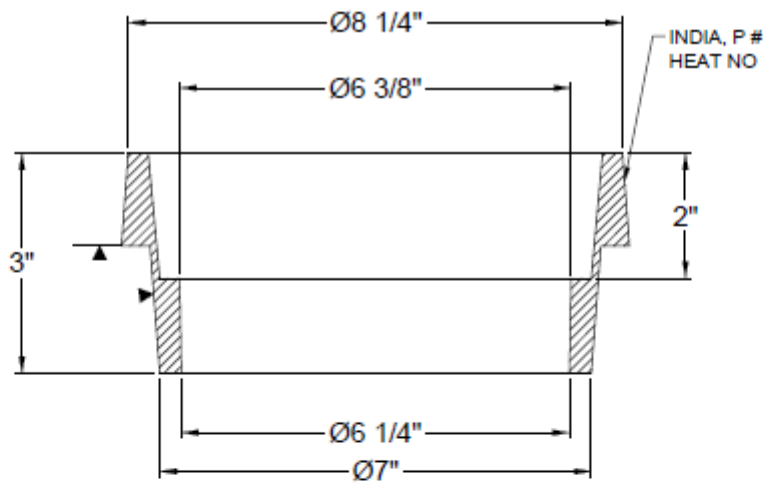

SEC. VIEW

Note:-

1. All the dimensions are in inches.
2. Material: Cast Iron as per ASTM A48 Class 30B.
3. Weight: 5.95 LBS..
4. Tolerance should be ± 0.0625 ", unless otherwise specified.
5. Refer Sigma QIP Doc.No : QA/QIP/MCC for manufacturing and inspection procedure.

BY RECEIVING THIS DRAWING THE RECDNTY AGREES THAT THIS DRAWING AND ITS CONTENTS REMAINS THE SOLE PROPERTY OF SIGMA CORPORATION. THE DRAWING IS TO BE USED IN CONNECTION WITH THE PROJECT FOR WHICH IT WAS ISSUED. IT IS TO BE REPRODUCED TO SIGMA'S DESIGN. THIS DRAWING IS LOANED SUBJECT TO RETURN ON DEMAND.

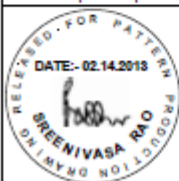

Rev	Date	Revision Record	Prepared	Approved
0	02.12.2013	Dimensions were wrong in original dwg. & now corrected from 23 1/2" to 24" & 26 3/4" to 27"	KSA	am
		Format Changed		

Product Group :-	MCC
Coating:-	PAINTED
Type :-	MCC SIZE AND CAST MARKS
Product Description:-	1" VALVE BOX RISER
Drawing Number :-	VB-2601
Rev :-	0

SIGMA
CREAM RIDGE, NEW JERSEY

DATE	02.12.2013	DRAWN BY	KSA
DRAWING FOR	SUBMITTAL	CHECKED BY	MSKASHIDSEY
SCALE	NTS	SHEET NO	1 OF 1
APPROVED BY			SR1

12306

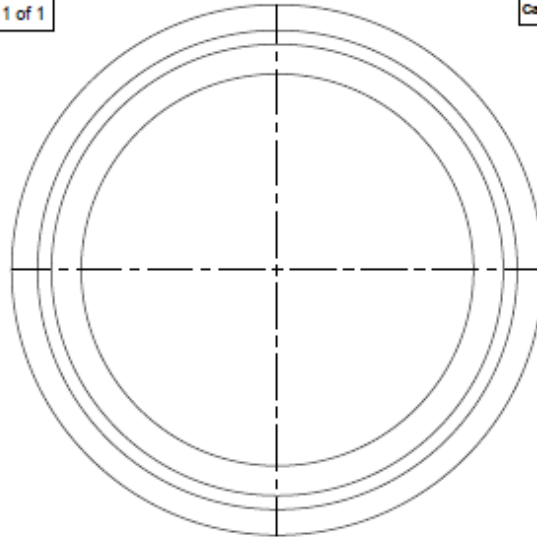

PLAN VIEW

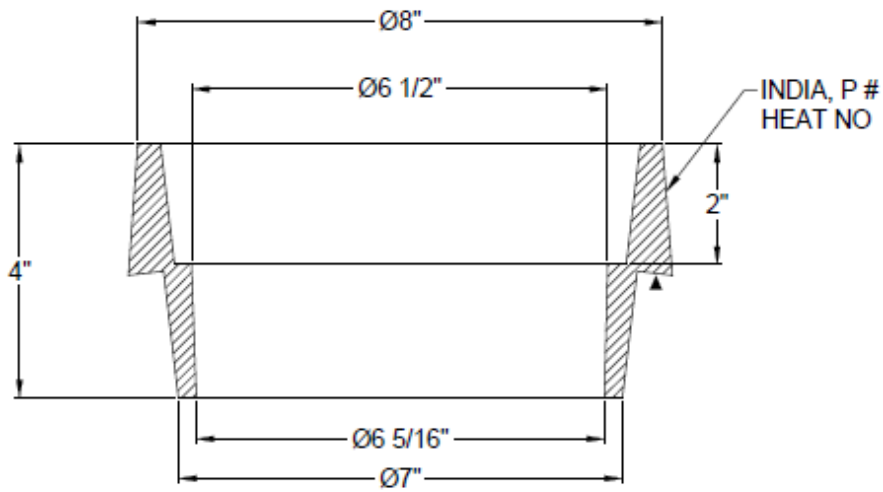

SEC. VIEW

Note:-

1. All the dimensions are in inches.
2. Material: Cast Iron as per ASTM A48 Class 30B.
3. Tolerance should be ± 0.0625 ", unless otherwise specified.
4. Refer Sigma QIP Doc.No : QA/QIP/MCC for manufacturing and inspection procedure.

BY NOTING THE DRAWING THE USER AGREES THAT THE DRAWING AND ITS CONTENTS REMAINS THE SOLE PROPERTY OF SIGMA CORPORATION. THIS DRAWING IS LOANED SUBJECT TO RETURN ON DEMAND.



Rev	Date	Revision Record	Prepared	Approved
0	02.12.2013	Format changed	MSK	SR1

All Radii & Fillets to be 0.125" (3mm) unless otherwise specified. All Draft angles to be 2° unless otherwise specified on drawing.	
Product Group ->	
MCC	
Coating ->	
PAINTED	
Type ->	
MCC SIZE AND CAST MARKS	
Product Description ->	
2" VALVE BOX RISER	
Drawing Number ->	Rev ->
VB-2602	0

		CREAM RIDGE, NEW JERSEY	
		DATE:	DRAWN BY:
02.12.2013		MS4	
DRAWING FOR:		CHECKED BY:	
SUBMITTAL		MSKASHISDEY	
SCALE:	SHEET NO:	APPROVED BY:	
NTS	1 OF 1	SR1	

COVER		RISER RING DIMENSIONS			CATALOG NUMBER
DIA.	THK.	A1	B	RISE	
23 1/2"	1"	23 3/4"	1"	1"	MH-2410
23 1/2"	1"	23 3/4"	1"	1 1/2"	MH-2415
23 1/2"	1"	23 3/4"	1"	2"	MH-2420
23 1/2"	1"	23 3/4"	1"	3"	MH-2430
23 1/2"	1"	23 3/4"	1"	4"	MH-2440
23 1/2"	1"	23 3/4"	1"	6"	MH-2460

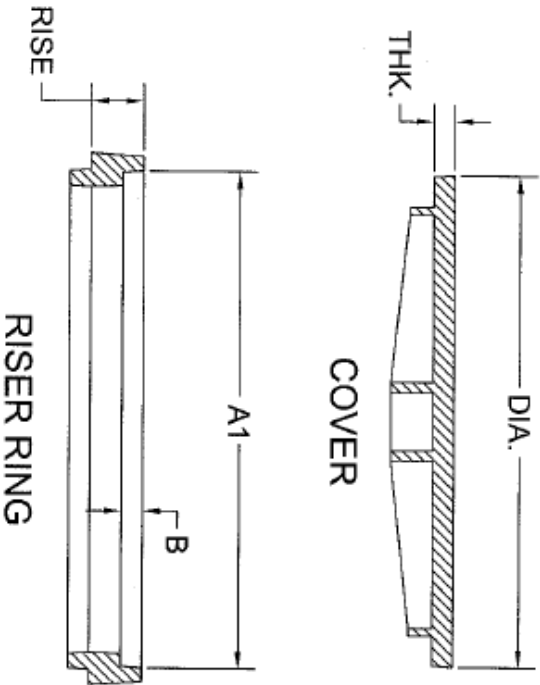

SIGMA
CORPORATION

(800) 824-4513
PO Box 519
Alexander City, AL 35011
(800) 738-2956
PO Box 1043
Rockingham, NC 28380

DRAWN BY: R.L. DATE: 6/19/2006

RISER RINGS

LOAD RATING:
Meets H20 Loading Standards
HEAVY DUTY

MATERIAL SPECIFICATION:
CAST IRON
ASTM A 48 CLASS 30B

OPEN AREA - SQ. IN.
N/A

DRAWING NO. 1057

CATALOG NUMBER

MH-2400

700 Goldman Drive
 Cream Ridge, NJ 08514



DRG. NO.
MH-3104N

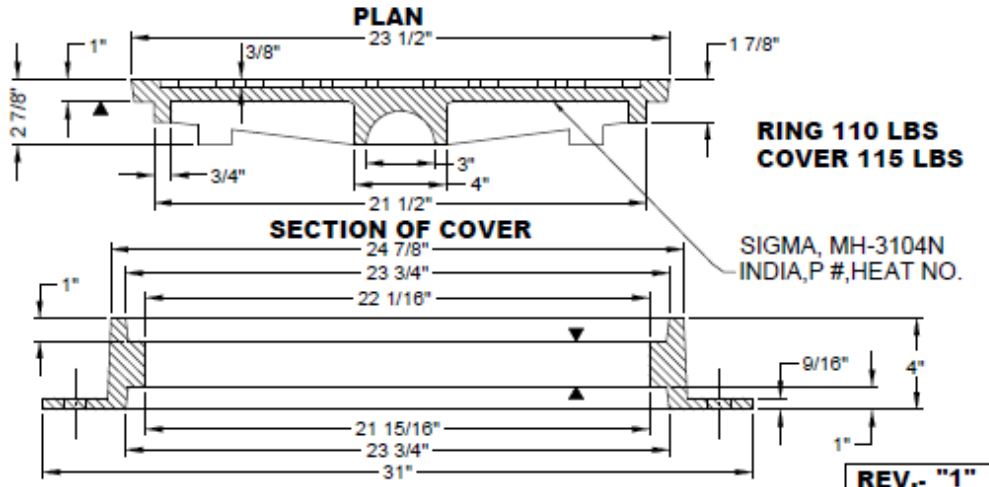
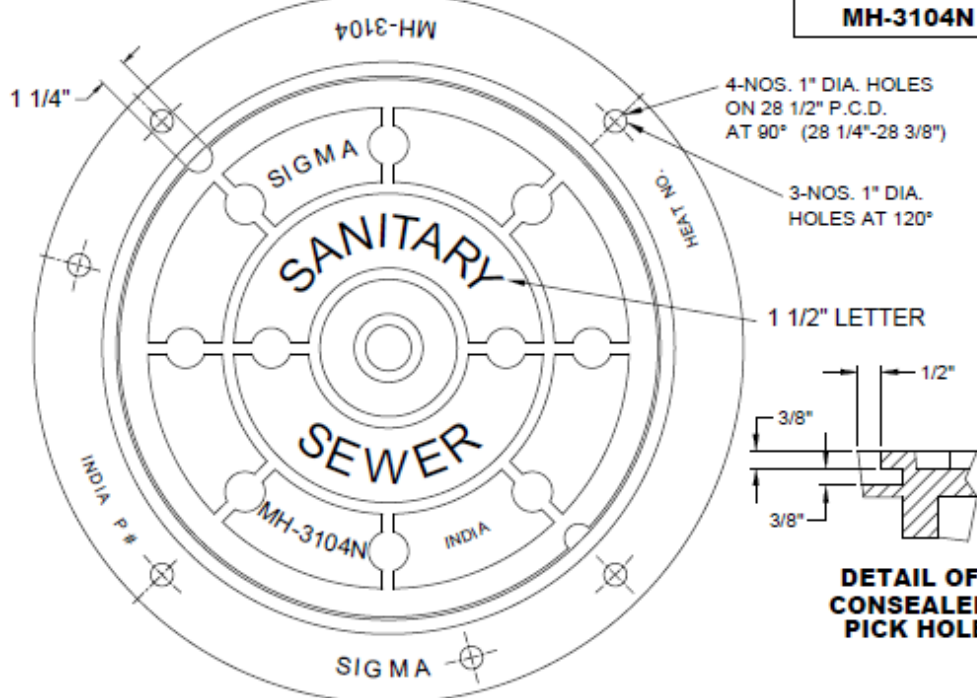

TOLERANCE SHOULD BE ±1/16", UNLESS OTHERWISE SPECIFIED

MATERIAL: Cast Iron ASTM A48 Class 30B Meets H20 Loading Standards		DESCRIPTION: C.I. MANHOLE REVERSIBLE RING & COVER MARKED "SANITARY SEWER"		REV.-"1" CHANGED TO REVERSIBLE FRAME FROM REGULAR TYPE FRAME VIDE E-MAIL DT. 10.05.02	
COATING: UNPAINTED				REV.-"2" GUSSET REMOVE VIDE EMAIL DT.-20.05.02	
				REV.-"3" ANCHOR HOLES ADDED VIDE EMAIL DT.-12.07.02	
DRN. BY: 10.06.02 N,DEBNATH		CHECKED BY: ASHIS DEY		REV.-"4" WT. IS CHANGED FROM 256 LBS TO 225 LBS AS PER EMAIL DT. 27.05.05	
		WEIGHT: 225 LBS(SET)		ISSUED ON: 17.01.05	
				APPVD. ON:	